



# قسم القوالب والسقالات FORMWORK & SCAFFOLDING DIVISION



مستر مشين  
Mister Machine  
خدمات تأجير متميزة Quality Equipment Hire

[www.mister-machine.com](http://www.mister-machine.com)







**Formwork & Scaffolding**  
+973 1770 5082, 1770 5050

[www.mister-machine.com](http://www.mister-machine.com)

|   |   |
|---|---|
| <b>Contact Details (Bahrain)</b>          | 4 |
| <b>Location Map (Maameer Head Office)</b> | 5 |

### **Formworks**

|                            |    |
|----------------------------|----|
| • Site Application         | 6  |
| • Modular Formwork         | 10 |
| • Roof Formwork            | 14 |
| • Circular Column Formwork | 15 |

### **Scaffolding**

|                       |    |
|-----------------------|----|
| • Scaffolding Section | 16 |
| • Jack Section        | 18 |

|                                       |    |
|---------------------------------------|----|
| <b>Contact Details (Saudi Arabia)</b> | 21 |
|---------------------------------------|----|





## KINGDOM OF BAHRAIN

### CONTACT DETAILS

#### ACCESS PLATFORMS

+973-17708177, 17705052

#### FORKLIFTS

+973-17708177, 17708170

#### GENERATORS AND COMPRESSORS

+973-17708160, 17705059

#### HEAVY EQUIPMENT

+973-17708177, 17705052

#### LIGHT EQUIPMENT

+973-17705058

#### FORMWORK AND SCAFFOLDING

+973-17708168

#### PORTABLE CABINS

+973-17708168

#### RAW MATERIALS

+973-17705085, 17708173

#### SKIPS

+973-17705061, 39797404

#### TRANSPORTATION AND LOGISTICS

+973-17705069

#### QUALITY USED EQUIPMENT FOR SALE

+973 39757554, 17708173, +966 55 8884575

## مملكة البحرين

### بيانات الاتصال

#### الرافعات الشخصية المتنقلة

+973 17708177, 17705052

#### الرافعات الشوكية

+973 17708177, 17708170

#### المولدات الكهربائية والضواغط

+973 17708160, 17705059

#### المعدات الثقيلة

+973 17708177, 17705052

#### المعدات الخفيفة

+973 17705058

#### القوالب والسقالات

+973 177 08168

#### كباين متنقلة

+973 17708168

#### المواد الخام

+973 17705085, 17708173

#### حاويات الأنقاض

+973 177 05061 - 39797404

#### النقل والخدمات اللوجستية

+973 17705069

#### بيع المعدات المستعملة الممتازة

+973 39757554, 17708173, +966 55 8884575

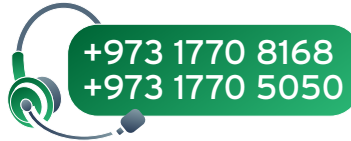

## BAHRAIN BRANCHES

### Maameer

Tel: +973 17708160, 17708168

Fax: +97317700086

Location: Bldg. 541, Rd.3417 Blk. 634, Maameer Industrial Area

GPS Map: 26.1267, 50.6050

### Muharraq

Tel: +973 17345020

Fax: +973 17346020

Location: Shop 1157b, Rd. 1021, Blk. 210, Muharraq

GPS Map: 26.2531, 50.6190

### Manama

Tel: +973 17240166

Fax: +973 17240155

Location: Shop 313, R. 336, Bli. 311, Manama

GPS Map: 26.2226, 50.5711

### Ras Zuwayed

Tel: +973 17705070, +973 17708177

Fax: +973 17703050

Location: Bldg. 49, Ave. 52, Blk. 952, Ras Zuwayed

GPS Map: 26.0792, 50.6238

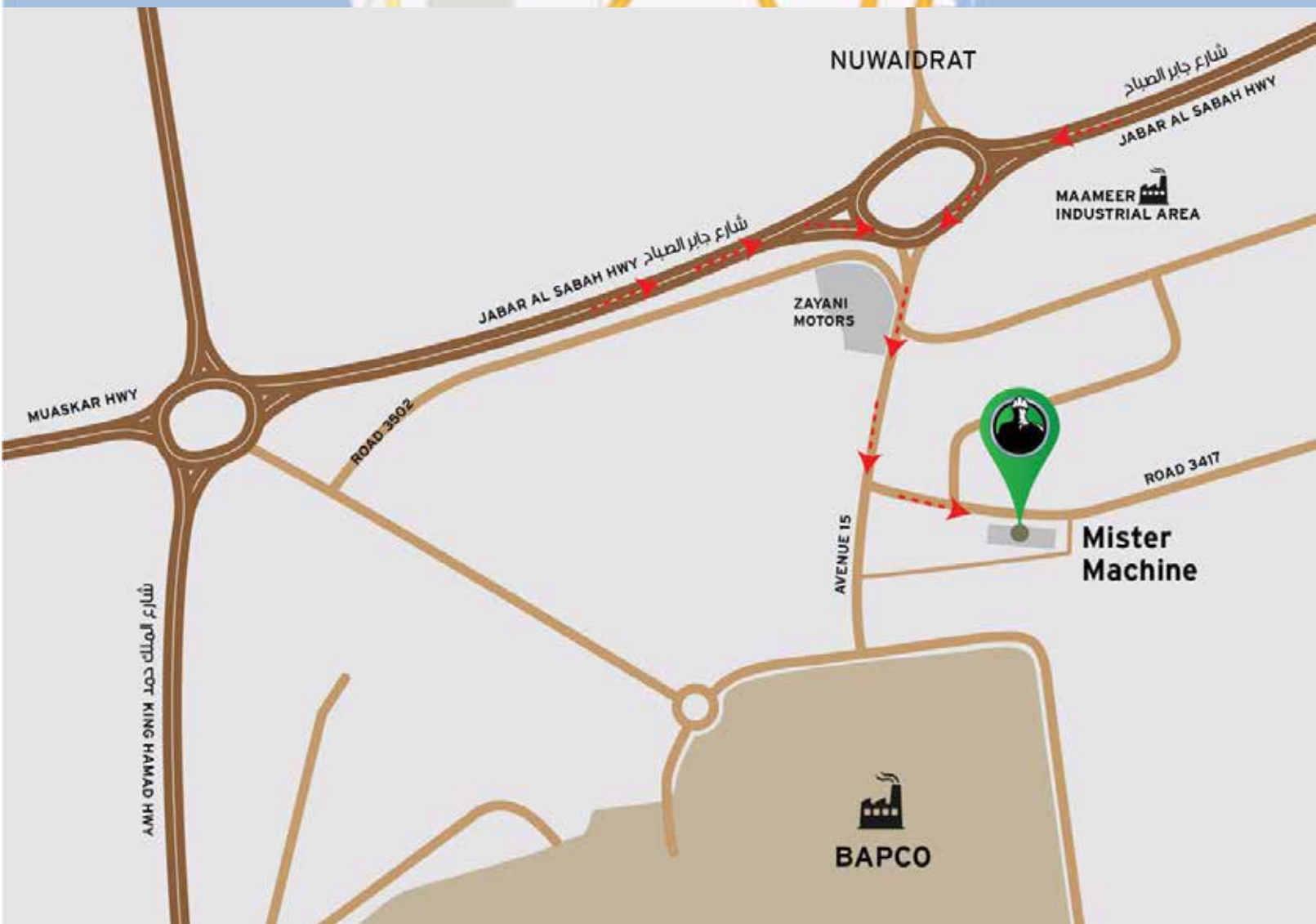



## SITE APPLICATIONS

## تطبيقات المواقع

### MISTER MACHINE®

- **QUALITY EQUIPMENT HIRE:** Hiring the best performance, most reliable Formwork, All our Formwork are the latest models.
- **SELECTION:** The biggest Equipment hirer in Bahrain.
- **COMPETITIVE HIRE RATES:** The Best Quality and Hire Rates in Bahrain.

#### 1) MODULAR PANELS:

- True to size in every shape and form every time.
- The panel heights of 75/ 125/ 150cm with varying widths give flexibility to Easily make any shape. Example: Footings, Columns, and Beams etc...
- No risk: Guaranteed to withstand large pressure loads & will not leak at the joints.

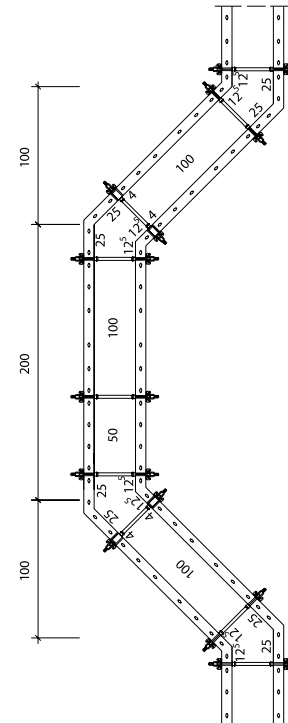

## 2) TYPICAL APPLICATIONS: تطبيقات متنوعة

- Making a column - any size ready for casting in 20 minutes.
- Polygonal system for making any circular wall or beam.
- Ground beam - any height, any length, any shape.
- A footing ready for casting in 5 minutes.

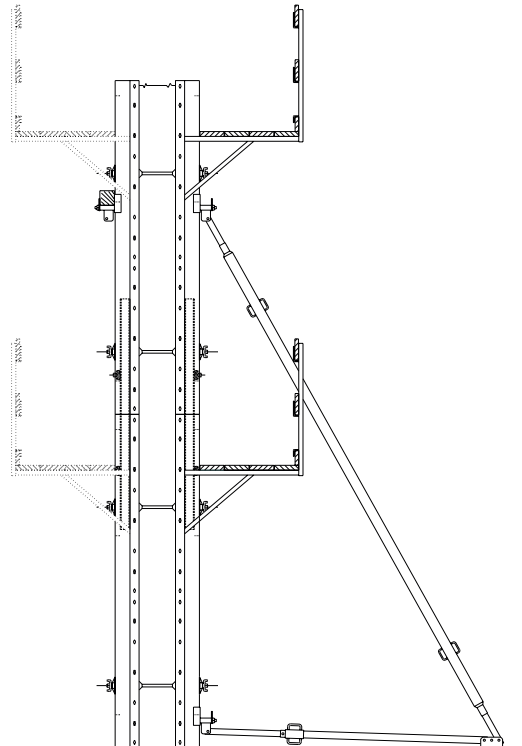
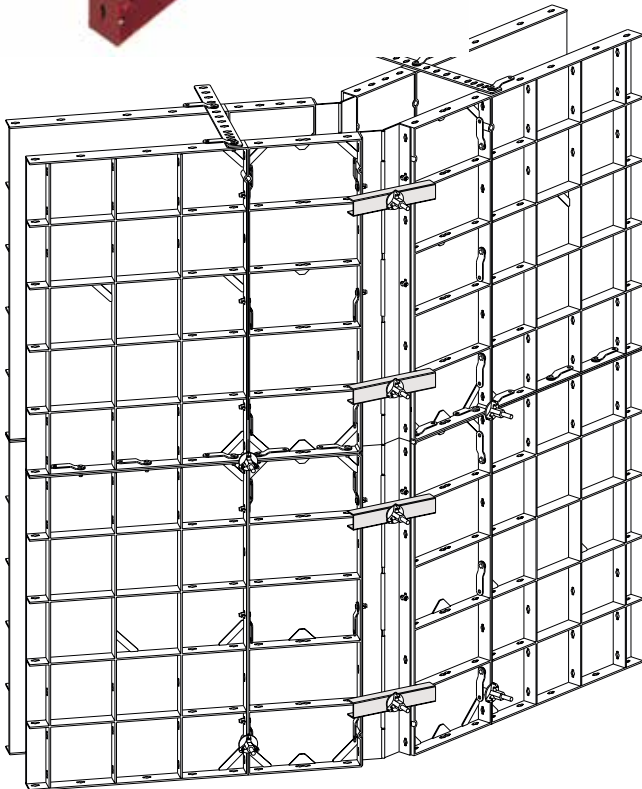

# قوالب الإنشاءات FORMWORK

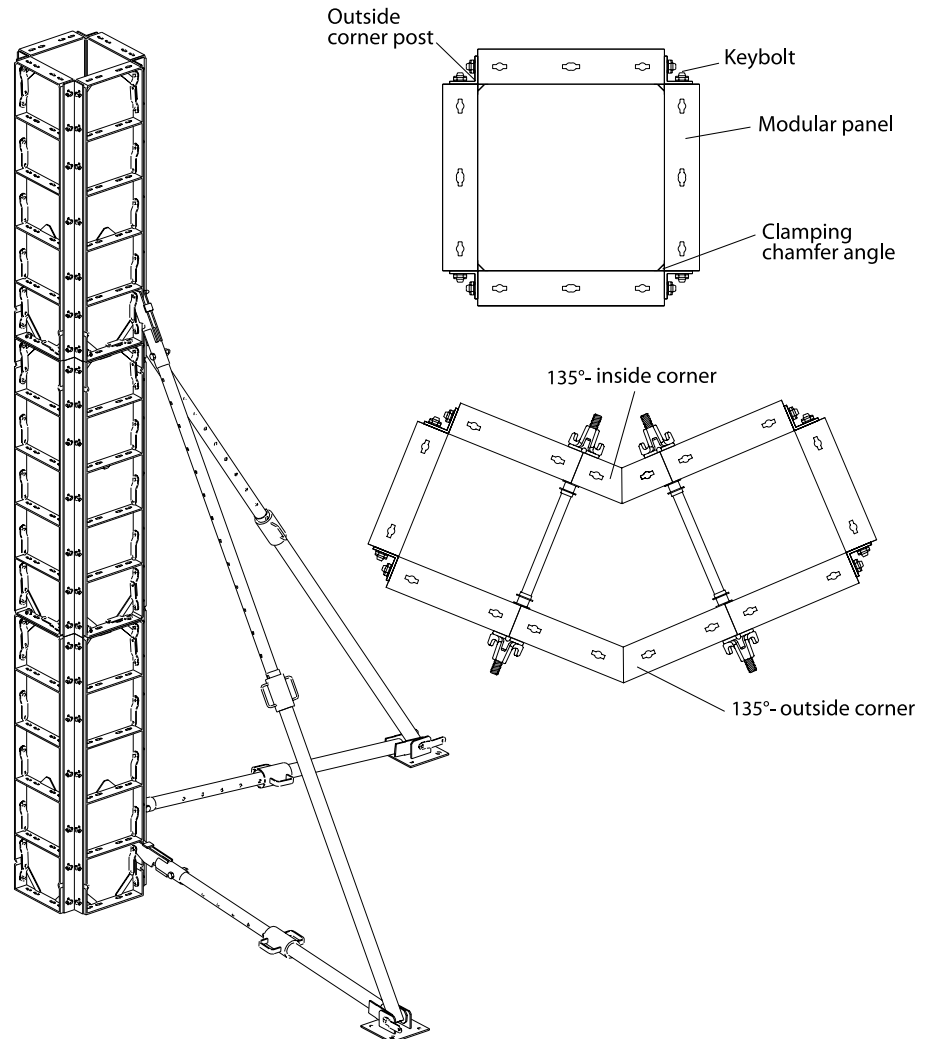

Please call: +973 1770 5082, 1770 5059  
email: [sales@mister-machine.com](mailto:sales@mister-machine.com) - website: [www.mister-machine.com](http://www.mister-machine.com)



# قوالب الإنشاءات FORMWORK

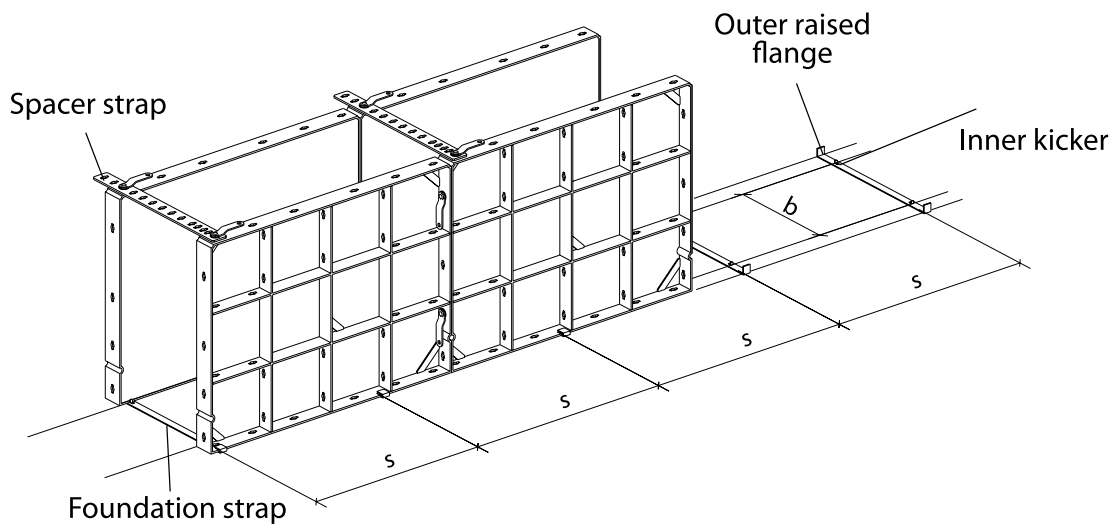

# قوالب الإنشاءات FORMWORK

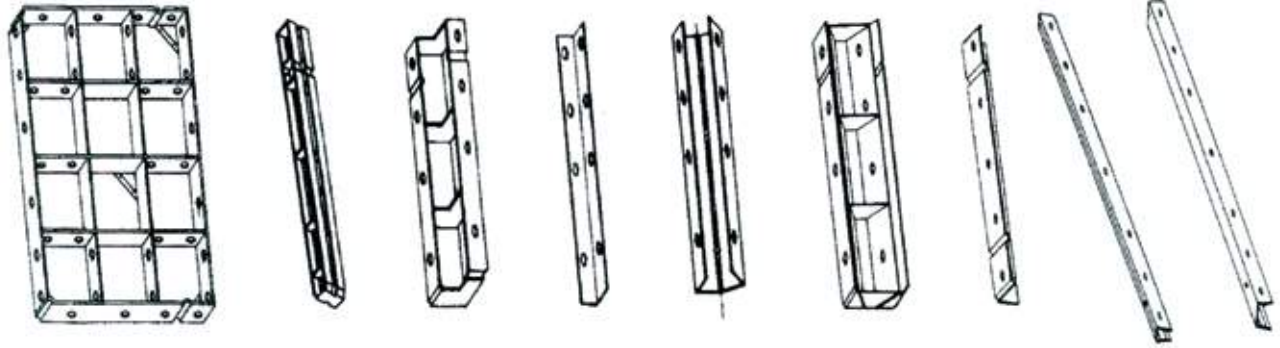

## MODULAR FORMWORKS

## قوالب المقاسات المتعددة

### MISTER MACHINE®

- **QUALITY EQUIPMENT HIRE:** Hiring the best performance, most reliable Equipment, All our Equipment are the latest models.
- **SELECTION:** The biggest Equipment hirer in Bahrain.
- **COMPETITIVE HIRE RATES:** The Best Quality and Hire Rates in Bahrain.

#### PASCHAL MODULAR PANELS - HEIGHT of 75 cm

| ART NO.      | DESCRIPTION  | WEIGHT (KG) |
|--------------|--|-------------|
| 100.001.1000 | Panel 100 x 75 cm                                    | 30.000      |
| 101.001.0750 | Panel 75 x 75 cm                                     | 24.100      |
| 101.001.0600 | Panel 60 x 75 cm                                     | 19.100      |
| 101.001.0500 | Panel 50 x 75 cm                                     | 16.800      |
| 101.001.0450 | Panel 45 x 75 cm                                     | 14.100      |
| 101.001.0400 | Panel 40 x 75 cm                                     | 13.100      |
| 101.001.0350 | Panel 35 x 75 cm                                     | 12.100      |
| 101.001.0300 | Panel 30 x 75 cm                                     | 11.100      |
| 101.001.0250 | Panel 25 x 75 cm                                     | 10.100      |
| 101.001.0200 | Panel 20 x 75 cm                                     | 9.100       |
| 101.001.0150 | Panel 15 x 75 cm                                     | 8.100       |
| 101.001.0100 | Panel 10 x 75 cm                                     | 7.100       |
| 101.003.0050 | Filler Post 5 x 75 cm                                | 5.400       |
| 101.005.0100 | Inside Corner Post 10 x 10 x 75 cm                   | 8.000       |
| 101.005.0150 | Inside Corner Post 15 x 15 x 75 cm                   | 9.600       |
| 101.006.0000 | Outside Corner Post 75 cm                            | 3.800       |
| 183.000.0040 | Inside Corner Post with oblong holes 15 x 15 x 75 cm | 9.600       |

#### ACCESSORIES - HEIGHT of 75 cm

| ART NO.      | DESCRIPTION   | WEIGHT (KG) |
|--------------|---|-------------|
| 101.007.0001 | Hinged corner post 9.5 x 9.5 x 75 cm without holes for ties | 10.600      |
| 101.007.0002 | Hinged corner post 9.5 x 9.5 x 75 cm with holes for ties    | 10.600      |
| 101.008.0200 | Panel for dismantling 20 x 75 cm (with 4 key bolts)         | 21.600      |
| 101.012.0005 | Filler Plate with opening for ties 8 x 75 cm                | 3.900       |
| 101.014.0001 | Polygonal Filler Post Inside 4,66 x 75 cm                   | 3.400       |
| 101.014.0002 | Polygonal Filler Post Outside 9,02 x 75 cm                  | 3.900       |

Please call: +973 1770 5082, 1770 5059

email: [sales@mister-machine.com](mailto:sales@mister-machine.com) - website: [www.mister-machine.com](http://www.mister-machine.com)

10



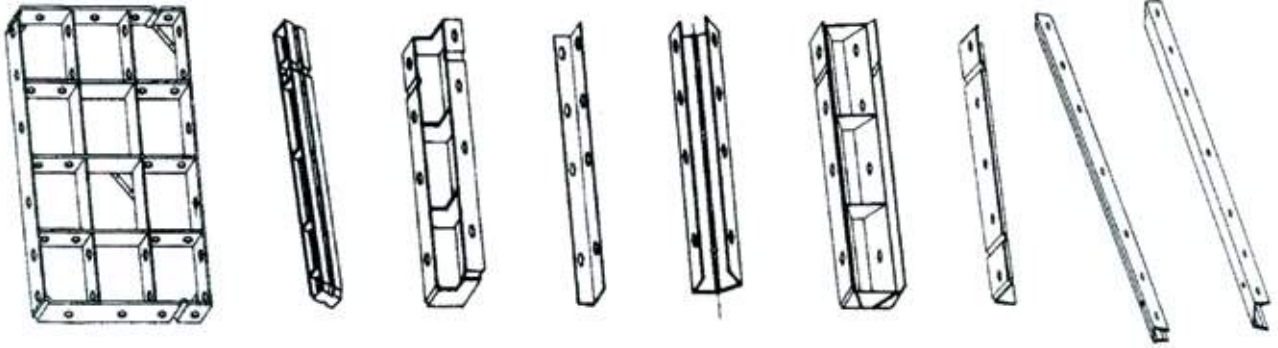

**PASCHAL MODULAR PANELS - HEIGHT of 125 cm**

| ART NO.      | DESCRIPTION   | WEIGHT (KG) |
|--------------|---|-------------|
| 103.001.1000 | Panel 100 x 125 cm                                    | 49.500      |
| 103.001.0750 | Panel 75 x 125 cm                                     | 37.500      |
| 103.001.0600 | Panel 60 x 125 cm                                     | 29.300      |
| 103.001.0500 | Panel 50 x 125 cm                                     | 26.300      |
| 103.001.0450 | Panel 45 x 125 cm                                     | 21.600      |
| 103.001.0400 | Panel 40 x 125 cm                                     | 20.100      |
| 103.001.0350 | Panel 35 x 125 cm                                     | 18.600      |
| 103.001.0300 | Panel 30 x 125 cm                                     | 17.100      |
| 103.001.0250 | Panel 25 x 125 cm                                     | 15.600      |
| 103.001.0200 | Panel 20 x 125 cm                                     | 14.100      |
| 103.001.0150 | Panel 15 x 125 cm                                     | 12.600      |
| 103.001.0100 | Panel 10 x 125 cm                                     | 11.100      |
| 103.003.0050 | Filler Post 5 x 125 cm                                | 8.600       |
| 103.005.0100 | Inside Corner Post 10 x 10 x 125 cm                   | 12.000      |
| 103.005.0150 | Inside Corner Post 15 x 15 x 125 cm                   | 16.000      |
| 103.006.0000 | Outside Corner Post 125 cm                            | 6.400       |
| 183.000.0041 | Inside Corner Post with oblong holes 15 x 15 x 125 cm | 15.000      |

**ACCESSORIES - HEIGHT of 125 cm**

| ART NO.      | DESCRIPTION  | WEIGHT (KG) |
|--------------|--|-------------|
| 103.007.0001 | Hinged corner post 9.5 x 9.5 x 125 cm without holes for ties | 17.700      |
| 103.007.0002 | Hinged corner post 9.5 x 9.5 x 125 cm with holes for ties    | 17.700      |
| 103.008.0200 | Panel for dismantling 20 x 125 cm (with 8 key bolts)         | 35.000      |
| 103.012.0005 | Filler Plate 8 x 125 cm                                      | 6.500       |
| 103.014.0001 | Polygonal Filler Post Inside 4,66 x 125                      | 5.800       |
| 103.014.0002 | Polygonal Filler Post Outside 9,02 x 125                     | 6.500       |

# قوالب الإنشاءات FORMWORK

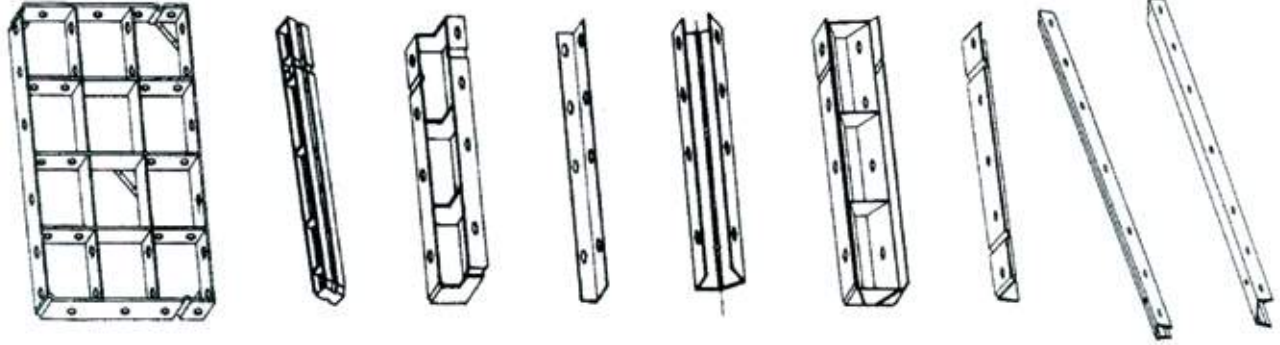

## MODULAR FORMWORKS

## قوالب المقاسات المتعددة

### MISTER MACHINE®

- **QUALITY EQUIPMENT HIRE:** Hiring the best performance, most reliable Equipment, All our Equipment are the latest models.
- **SELECTION:** The biggest Equipment hirer in Bahrain.
- **COMPETITIVE HIRE RATES:** The Best Quality and Hire Rates in Bahrain.

### PASCHAL MODULAR PANELS - HEIGHT of 150 cm

| ART NO.      | DESCRIPTION   | WEIGHT (KG) |
|--------------|---|-------------|
| 104.001.1000 | Panel 100 x 150 cm                                    | 59.000      |
| 104.001.0750 | Panel 75 x 150 cm                                     | 44.500      |
| 104.001.0600 | Panel 60 x 150 cm                                     | 35.400      |
| 104.001.0500 | Panel 50 x 150 cm                                     | 31.400      |
| 104.001.0450 | Panel 45 x 150 cm                                     | 25.800      |
| 104.001.0400 | Panel 40 x 150 cm                                     | 23.800      |
| 104.001.0350 | Panel 35 x 150 cm                                     | 22.100      |
| 104.001.0300 | Panel 30 x 150 cm                                     | 20.400      |
| 104.001.0250 | Panel 25 x 150 cm                                     | 18.700      |
| 104.001.0200 | Panel 20 x 150 cm                                     | 16.900      |
| 104.001.0150 | Panel 15 x 150 cm                                     | 15.200      |
| 104.001.0100 | Panel 10 x 150 cm                                     | 13.400      |
| 104.003.0050 | Filler Post 5 x 150 cm                                | 11.000      |
| 104.005.0100 | Inside Corner Post 10 x 10 x 150 cm                   | 13.000      |
| 104.005.0150 | Inside Corner Post 15 x 15 x 150 cm                   | 19.200      |
| 104.006.0000 | Outside Corner Post 150 cm                            | 7.600       |
| 183.000.0042 | Inside Corner Post with oblong holes 15 x 15 x 150 cm | 19.000      |

### ACCESSORIES - HEIGHT of 150 cm

| ART NO.      | DESCRIPTION  | WEIGHT (KG) |
|--------------|--|-------------|
| 104.007.0001 | Hinged corner post 9.5 x 9.5 x 150 cm without holes for ties | 21.200      |
| 104.007.0002 | Hinged corner post 9.5 x 9.5 x 150 cm with holes for ties    | 21.200      |
| 104.008.0200 | Panel for dismantling 20 x 150 cm (with 8 key bolts)         | 42.100      |
| 104.012.0005 | Filler Plate 8 x 150 cm                                      | 7.800       |
| 104.014.0001 | Polygonal Filler Post Inside 4,66 x 150 cm                   | 6.900       |
| 104.014.0002 | Polygonal Filler Post Outside 9,02 x 150 cm                  | 7.800       |

Please call: +973 1770 5082, 1770 5059

email: [sales@mister-machine.com](mailto:sales@mister-machine.com) - website: [www.mister-machine.com](http://www.mister-machine.com)

12



Formwork & Scaffolding

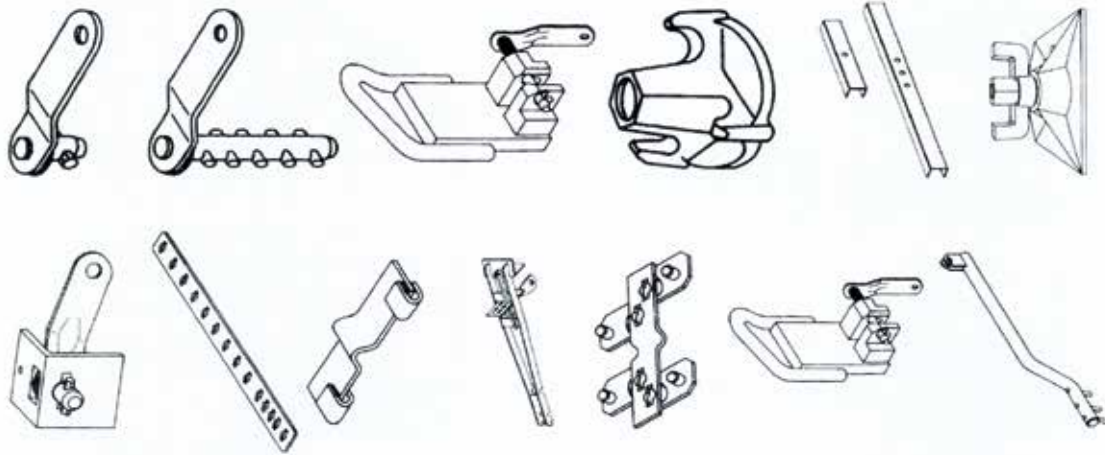

**PASCHAL CONNECTING PIECES AND TENSION MATERIALS**

| ART NO.      | DESCRIPTION   | WEIGHT (KG) |
|--------------|---|-------------|
| 131.000.0750 | Connecting yoke 20 x 75 cm  | 11.800      |
| 131.000.1250 | Connecting yoke 20 x 125 cm   | 18.700      |
| 132.000.0750 | Connecting yoke variable 75- 100 cm   | 16.000      |
| 133.000.0000 | Prop head 20 x 25 cm  | 5.150       |
| 189.001.0100 | Key -bolt   | 0.190       |
| 189.001.0105 | 5 Pin key-bolts   | 0.300       |
| 189.006.0650 | Tie-rod: DW 15 x 65 cm  | 0.900       |
| 189.006.1000 | Tie-rod: DW 15 x 100 cm   | 1.400       |
| 189.006.1350 | Tie-rod: DW 15 x 135 cm   | 1.850       |
| 189.006.1500 | Tie-rod: DW 15 x 150 cm   | 2.100       |
| 189.001.0001 | Wing nut DW 15  | 0.460       |
| 189.001.0059 | Plate with ball-and-socket joint DW 15, 10 x 14 cm<br>(inclination max .12) | 1.100       |
| 189.001.0020 | Spacer strap 6 - 50 cm  | 1.500       |
| 189.001.0021 | Spacer strap 50 - 120 cm  | 3.500       |
| 189.001.0086 | Tie rod guide   | 0.750       |
| 189.001.0071 | Bracing channel support bracket   | 0.600       |
| 189.001.0066 | Bracing channel 35 cm   | 1.500       |
| 189.001.0067 | Bracing channel 85 cm   | 4.000       |
| 180.000.0008 | Waling clamp with wedge (for walers 8 - 20 cm)                              | 2.700       |
| 189.001.0017 | Fixing bracket for plywood 21 mm  | 0.450       |
| 189.001.0013 | Wall offset -plate 5 cm   | 1.200       |
| 189.002.0008 | Crane Lifting clamp KZ with GS test mark                                    | 4.000       |
| 189.003.0000 | Assembly tool   | 3.900       |
| 189.004.0013 | Platform bracket cpl.90 cm  | 11.000      |
| 189.005.0001 | Adjustable prop with support (CPL 170-290 cm)                               | 28.500      |
| 189.005.0002 | Foot Plate CPL  | 3.000       |
| 180.000.0025 | Suspending piece for props cpl.   | 2.500       |
| 949.000.0003 | Paschal joint Filing Agent 310 ml   | 0.430       |
| 941.018.0051 | Paschal Formwork Hammer   |             |
| 940.030.0245 | Wooden - Girder H20, 2.45 m   | 11.300      |
| 940.030.0290 | Wooden - Girder H20, 2.90 m   | 13.400      |
| 940.030.0390 | Wooden - Girder H20, 3.90 m   | 18.000      |
| 940.030.0600 | Wooden - Girder H20, 6.00 m   | 27.600      |

Please call: +973 1770 5082, 1770 5059

email: [sales@mister-machine.com](mailto:sales@mister-machine.com) - website: [www.mister-machine.com](http://www.mister-machine.com)

# قوالب الإنشاءات FORMWORK

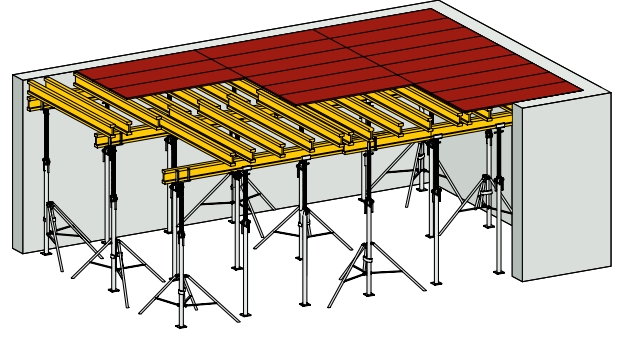
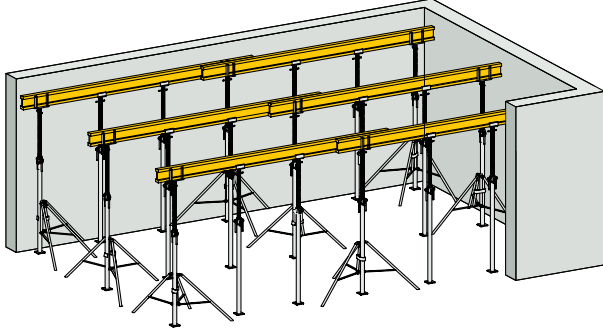

## ROOF FORMWORKS

## قوالب الأسقف

### MISTER MACHINE®

- **QUALITY EQUIPMENT HIRE:** Hiring the best performance, most reliable Equipment, All our Equipment are the latest models.
- **SELECTION:** The biggest Equipment hirer in Bahrain.
- **COMPETITIVE HIRE RATES:** The Best Quality and Hire Rates in Bahrain.

### DECK SYSTEM FOR CAST IN-SITU SLABS

#### Wooden I-Beam (Wooden Girder H20)

- Suitable for shuttering any shape of reinforced concrete (R.C) slabs.
- The number of jacks can be reduced by 50%.

**PASCHAL-DECK is a flexible slab Formwork system consisting of three main components.**

1. Plywood
2. Wooden I-beam (H20 girder)
3. Prop.

The Formwork can be used for different slab thickness. The plywood is supported by the H20 girders (here cross girders). The same timber girders are also used as the main girder to support the cross girders. Support for the main girders is achieved by the props. Depending on the load the single parts (girders, props) can be positioned at the statically required distance (see table).

The flexibility in longitudinal direction of the girders (main and cross girders) is achieved by overlapping of the exiting girders.

The static details for the H20 girders are:

Permissible bending moment:  $m = 5.0 \text{ kNm}$ .

Permissible transverse Force:  $Q = 11 \text{ KN}$ .

| LENGTH | WEIGHT (kg) |
|--------|-------------|
| 2.45 m | 11.40       |
| 2.90 m | 13.50       |
| 3.30 m | 15.40       |
| 3.60 m | 16.80       |
| 3.90 m | 18.10       |
| 4.90 m | 22.80       |
| 6.00 m | 27.90       |

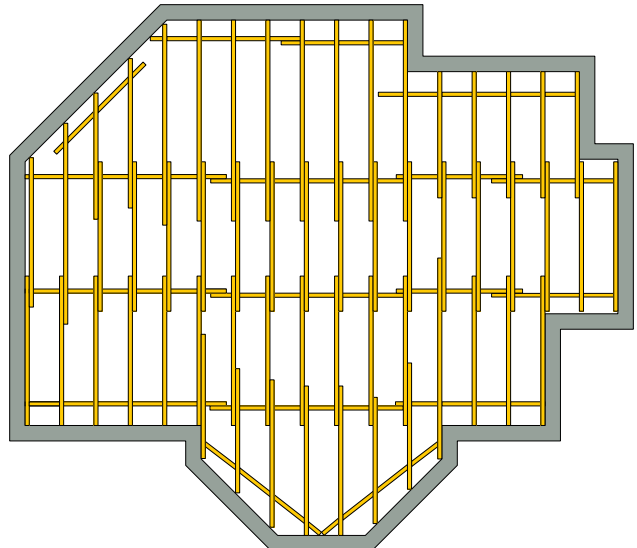

CIRCULAR COLUMN FORMWORKS

القوالب الدائرية

CIRCULAR COLUMN FORMWORK

CIRCULAR COLUMN: Diameter 25 cm

| ART NO.      | DESCRIPTION         | WEIGHT (kg) |
|--------------|---------------------|-------------|
| 145.025.0750 | D25 cm x H = 75 cm  | 65.000      |
| 145.025.1250 | D25 cm x H = 125 cm | 90.000      |
| 145.025.1500 | D25 cm x H = 150 cm | 101.00      |

CIRCULAR COLUMN: Diameter 30 cm

| ART NO.      | DESCRIPTION         | WEIGHT (kg) |
|--------------|---------------------|-------------|
| 145.030.0750 | D30 cm x H = 75 cm  | 70.000      |
| 145.030.1250 | D30 cm x H = 125 cm | 97.000      |
| 145.030.1500 | D30 cm x H = 150 cm | 108.000     |

CIRCULAR COLUMN: Diameter 35 cm

| ART NO.      | DESCRIPTION         | WEIGHT (kg) |
|--------------|---------------------|-------------|
| 145.035.0750 | D35 cm x H = 75 cm  | 74.000      |
| 145.035.1250 | D35 cm x H = 125 cm | 104.000     |
| 145.035.1500 | D35 cm x H = 150 cm | 116.000     |

CIRCULAR COLUMN: Diameter 40 cm

| ART NO.      | DESCRIPTION         | WEIGHT (kg) |
|--------------|---------------------|-------------|
| 145.040.0750 | D40 cm x H = 75 cm  | 78.000      |
| 145.040.1250 | D40 cm x H = 125 cm | 110.000     |
| 145.040.1500 | D40 cm x H = 150 cm | 124.000     |

CIRCULAR COLUMN: Diameter 45 cm

| ART NO.      | DESCRIPTION         | WEIGHT (kg) |
|--------------|---------------------|-------------|
| 145.045.0750 | D45 cm x H = 75 cm  | 82.000      |
| 145.045.1250 | D45 cm x H = 125 cm | 117.000     |
| 145.045.1500 | D45 cm x H = 150 cm | 131.000     |



**Circular Columns:**

- Half and half makes a perfect column. The big key bolt simply turns two identical steel half shells into a perfect round .10 minutes & the column is ready for concreting.
- No risk: Guaranteed to withstand large pressure loads & will not leak at the joints.
- Open it, and paint it! No needs for plastering column result are better & overall cost is 50% cheaper than wood due to the savings in labour charges.

## SCAFFOLDING SECTION

## السقالات

**MISTER MACHINE®**

- **QUALITY EQUIPMENT HIRE:** Hiring the best performance, most reliable Equipment, All our Equipment are the latest models.
- **SELECTION:** The biggest Equipment hirer in Bahrain.
- **COMPETITIVE HIRE RATES:** The Best Quality and Hire Rates in Bahrain.

**1) SCAFFOLDING:**

The Frame Type Scaffold System is very versatile and very simple to use. It is suitable for different kinds of building structures.

**Components:**

- Scaffolding Frame
- Scaffolding Xross Brace.
- Scaffolding Joint Pin.
- Scaffolding Wheel 6" (castor Wheel)
- Scaffolding Jack-base.
- Scaffolding Platform - steel.
- Scaffolding Platform - wood.
- Scaffolding U-head.
- Scaffolding Pipe.
- Scaffolding Couplers - swivel type.
- Scaffolding Couplers - right angel type.

**One Scaffolding Set Consists of the Following Only:**

- Scaffolding Frames - 2 numbers.
- Scaffolding Xross Braces - 2 numbers.
- Scaffolding Joint Pins - 4 numbers.

**Mobile Towers-steel Type:**

Can be made up using the above Components as follows:

- Scaffolding Wheels
- Scaffolding Sets (Frames +Xross Braces + Joint Pins)
- Scaffolding Platforms-steel.



# السقالات SCAFFOLDING

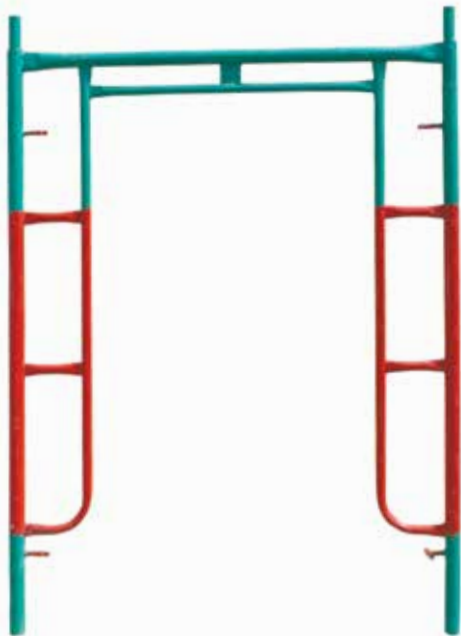

## JACK SECTION

## الدعائم الثابتة

**MISTER MACHINE®**

- **QUALITY EQUIPMENT HIRE:** Hiring the best performance, most reliable Equipment, All our Equipment are the latest models.
- **SELECTION:** The biggest Equipment hirer in Bahrain.
- **COMPETITIVE HIRE RATES:** The Best Quality and Hire Rates in Bahrain.

**2) JACKS:**

- A. Jacks - Small(1.00 to 1.50 meters)
- B. Jacks - Medium (1.50 to 2.50 meters)
- C. Jacks - Standard (2.50 to 3.90 meters)
- D Jacks - Long (4.00 to 6.00 meters)

**3. CLAMPS:**

- A. The normal blacksmith type
- B. The carpenters type

**4. TIE ROD SYSTEM:**

One Tie Rod Set Consists of the Following:-

- A. Tie Rod - 1 number
- B. Tie Plates - 2 numbers
- C. Wing Nuts - 2 numbers

**5. TIE ROD SYSTEM ACCESSORIES (FOR SALE ONLY):**

- A. PVC Tubes & PVC Cones: So that the Tie Rods can be recovered after concreting.
- B. Water Stop: Used when watertight walls have to be constructed.

# السقالات SCAFFOLDING





# KINGDOM OF SAUDI ARABIA

## CONTACT DETAILS

### ACCESS PLATFORMS

055 733 3875, 053 533 3045

### FORKLIFTS

055 733 3875, 050 079 3332

### GENERATORS AND COMPRESSORS

055 733 3875, 050 079 3332

### HEAVY EQUIPMENT

053 533 3045

### PORTABLE CABINS

055 878 1119, 013 808 4415

### TRANSPORTATION AND LOGISTICS

053 533 3045

### QUALITY USED EQUIPMENT

055 888 4575

# المملكة العربية السعودية

## بيانات الاتصال

### الرافعات الشخصية المتنقلة

٠٥٣ ٥٣٣ ٣٠٤٥ - ٠٥٥ ٧٣٣ ٣٨٧٥

### الرافعات الشوكية

٠٥٠ ٧٩٣ ٣٣٢ - ٠٥٥ ٧٣٣ ٣٨٧٥

### المولدات الكهربائية والضواغط

٠٥٠ ٧٩ ٣٣٣٢ - ٠٥٥ ٧٣٣ ٣٨٧٥

### المعدات الثقيلة

٠٥٣ ٥٣٣ ٣٠٤٥

### الكبائن متنقلة

٠٥٥ ٨٧٨ ١١١٩ - ٠١٣ ٨٠٨ ٤٤١٥

### النقل والخدمات اللوجستية

٠٥٣ ٥٣٣ ٣٠٤٥

### معدات مستخدمة ممتازة

٠٥٥ ٨٨٨ ٤٥٧٥

**24 Hours Hotline:** 055 878 1119

Email: [awal@mister-machine.com](mailto:awal@mister-machine.com)

Website: [www.mister-machine.com](http://www.mister-machine.com)

### Al Khobar Branch

Tel : 013 808 4412, 013 808 4413

013 808 4415, 013 808 4419

P.O. Box: 8146, Al Khobar 34623

### Address

Warehouse, Madar Industrial Area

King Khalid Road, Al Khobar,

Near Al Thuqba Industrial Area

Kingdom of Saudi Arabia

**GPS Map:** 26.2443, 50.2003

**الخط الساخن ٢٤ ساعة:** ٠٥٥ ٨٧٨ ١١١٩

[awal@mister-machine.com](mailto:awal@mister-machine.com)

[www.mister-machine.com](http://www.mister-machine.com)

### فرع الخبر

هاتف: ٠١٣ ٨٠٨ ٤٤١٢ - ٠١٣ ٨٠٨ ٤٤١٣

٠١٣ ٨٠٨ ٤٤١٩ - ٠١٣ ٨٠٨ ٤٤١٥

ص.ب: ٨١٤٦، الخبر ٣٤٦٢٣

### العنوان

مستودع، منطقة مدار الصناعية

طريق الملك خالد، الخبر

بالقرب من منطقة الثقبة الصناعية

المملكة العربية السعودية

خريطة تحديد الموقع: ٢٦.٢٤٤٣، ٥٠.٢٠٠٣

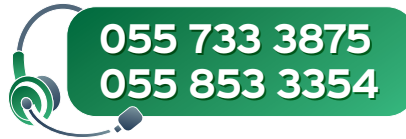

## EQUIPMENT DIVISIONS (BAHRAIN)

### ACCESS PLATFORMS

- Articulated Boom Lifts/ Man Lifts
- Telescopic Boom Lifts/ Man Lifts
- Scissor Lifts (Diesel/ Battery)

### FORKLIFTS

- Forklifts (Diesel/ Battery/ Lpg)
- Reach Trucks
- Telescopic Handlers (Loadall)

### FORMWORKS AND SCAFFOLDING

- Modular Formworks
- H-Beams (Wooden Girders)
- Circular Column Formworks
- Scaffolding Sets, and Jacks (Props)
- Proof Tested Scaffold Boards

### GENERATORS AND COMPRESSORS

- Generators (1 Phase/ 3 Phase)
- Air Compressors (Diesel/ Electric)
- Portable Fuel Tanks
- Lighting Towers

### HEAVY EQUIPMENT

- Compaction/ Rollers
- Cranes, Truck Cranes
- Earth Moving Equipment
- Trucks and Trailers
- Tankers

### LIGHT EQUIPMENT

- Cleaning and Cutting Equipment
- Electric Power Tools
- Fixing Tools
- Ladders and Lifting Equipment
- Compactor Plates and Concrete Vibrators
- Painting and Decorating Equipment
- Plumbing Equipment
- Rebar Bending and Cutting Equipment
- Water Pumps and Welding Equipment

### PORTABLE CABINS

- Portable Cabins, Guard Rooms
- Portable Toilets

### RAW MATERIALS

- Sale of Desert Fill, Stones, Sand, and Aggregates

### SKIPS

- Skip Bins/ Dumpsters
- Skip Loader Trucks
- Refuse Compactor Truck

### TRANSPORTATION AND LOGISTICS

- Transport of Equipment, and General Cargo
- Transport of Raw Materials

### QUALITY USED EQUIPMENT

- Sale of Used Power Tools, Generators, Compressors, Forklifts, Heavy Equipment, Skips, etc.

## أقسام المعدات (البحرين)

### الرافعات الشخصية المتنقلة

- رافعات سلة مفصليّة
- رافعات سلة تلسكوبية
- الرافعات المقصية (ديزل / بطارية)

### الرافعات الشوكية

- الرافعات الشوكية (ديزل، بطارية، غاز)
- رافعات المخازن الشوكية
- رافعات المناولة التلسكوبية

### قوالب الخرسانة والسقالات

- قوالب المقاسات المتعددة
- دعائم الأسقف الخشبية
- القوالب الدائرية
- أطقم السقالات والدعائم الثابتة
- ألواح / دوسات خشبية

### المولدات والضاغطات

- مولدات كهربائية 1 فيز، 3 فيز
- ضاغطات الهواء "كمبريسرات"
- خزانات ديزل متنقلة
- أبراج اللانارة

### المعدات الثقيلة

- مدارج الطرق
- الرافعات المتنقلة
- معدات الحفر والنقل الثقيلة
- القاطرات والمقطورات
- الصهاريج

### المعدات الخفيفة

- معدات التنظيف، معدات التقطيع
- المعدات الكهربائية
- أدوات التوصيل
- السلالم - معدات الرفع
- المعدات الداكنة وهزازة الكونكريت
- معدات الصباغة والديكور
- معدات السباكة
- معدات تقويس وتقطيع حديد التسليح
- مضخات المياه - معدات اللحام

### الكبائن متنقلة

- كبائن متنقلة، كبائن الحراس
- مراحيض متنقلة

### المواد الخام

- بيع الدفان البري، الصخور، الرمل، الكونكريت

### حاويات المخلفات

- حاويات المخلفات
- شاحنات نقل الحاويات
- شاحنات كيس المخلفات

### النقل والخدمات اللوجستية

- نقل المعدات الأثقل، وجميع أنواع البضائع
- نقل الدفان البري

### بيع المعدات المستعملة الممتازة

- بيع معدات كهربائية، رافعات شخصية، مولدات كهرباء، كمبريسرات، رافعات شوكية، معدات ثقيلة، حاويات الأنقاض، إلخ

